

Intelligent Proximity Alert System

# IPAS SE USER MANUAL



<b>1. Basic Information</b>	
1-1. Definition of IPAS .....	3
1-2. Components .....	4
1-3. Abbreviation .....	5
<b>2. Safety Warnings</b> .....	<b>6</b>
<b>3. Installation</b>	
3-1. How to Install (Common to all Products) .....	7 ~ 9
3-2. S-Mode/ Single VT .....	10
3-3. S-Mode/ Multi VTs .....	11
3-4. E-Mode/ Static Shaping .....	12
3-5. E-Mode/ Dynamic Shaping .....	13
3-6. ZT/ FZT .....	14
3-7. DZT .....	15
<b>4. Setting</b>	
4-1. IND+ .....	16
4-2. IND+/ S-Mode Setting .....	17
4-3. IND+/ E-Mode Setting .....	18 ~ 19
4-4. IND+/ Add-on Setting .....	20
4-5. IND+/ System Setting .....	21
4-6. PT .....	22
4-7. ZT/ FZT .....	23
4-8. KIGIS®Manager Quick Guide .....	24
<b>5. Prior to Error Reporting</b> .....	<b>25</b>
<b>6. Specifications</b> .....	<b>26</b>

## 1-1. BasicInformation | Definition of IPAS

---

IPAS(Intelligent Proximity Alert System) utilizes UWB technology to precisely measure the distance between vehicle tags and pedestrian tags and provides two-way approach alerts to both pedestrians and drivers to prevent collisions that may occur in industrial sites.

IPASSE provides effective and safe work environment by allowing precise setting of danger zones and caution zones by considering complex conditions such as vehicle driving direction and site environment.

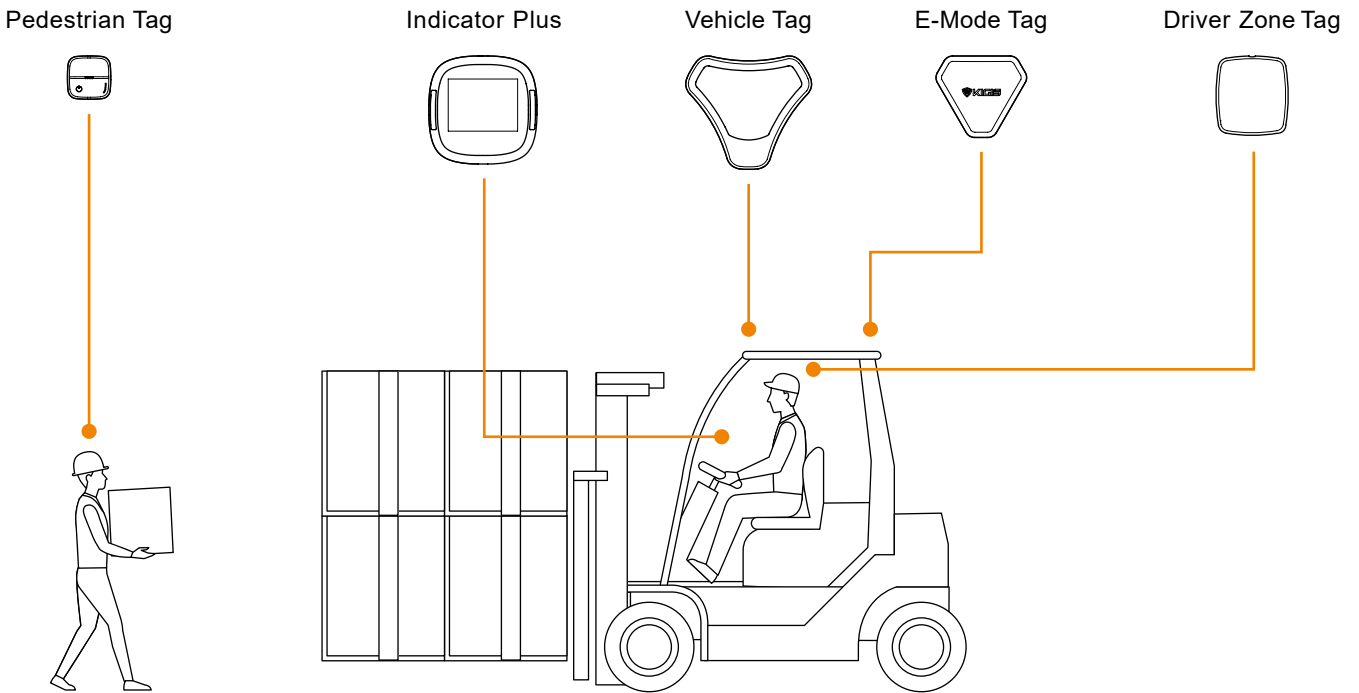



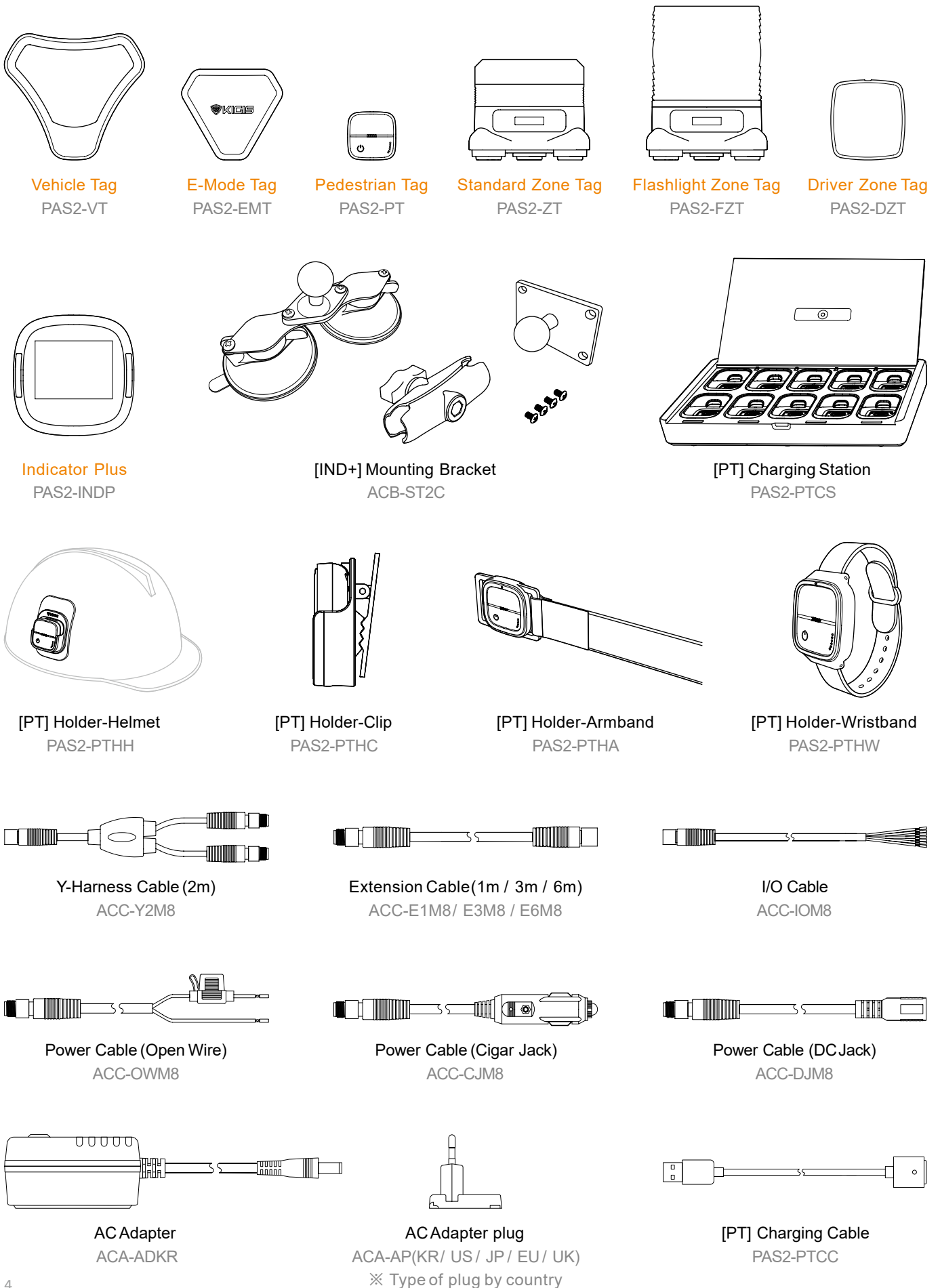



## 1-2. BasicInformation | Components

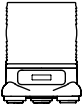

## 1-3. BasicInformation | Abbreviation

### ● Product Names

Product	Product Name	Abbreviation	Description
	Vehicle Tag	VT	Communication tag top mounted on the vehicle
	Extended-Mode Tag	EMT	Assistant Communication tag top mounted on the vehicle
	Pedestrian Tag	PT	Communication tag carried by workers
	Standard Zone Tag	ZT	Standard Type Zonal Communication tag installed at facility/area
	Flashlight Zone Tag	FZT	Flashlight Type Zonal Communication tag installed at facility/area
	Driver Zone Tag	DZT	PT shielding device installed inside the cabin
	Indicator Plus	IND+	Alarm/function setting device installed inside the vehicle

### ● Operation Modes

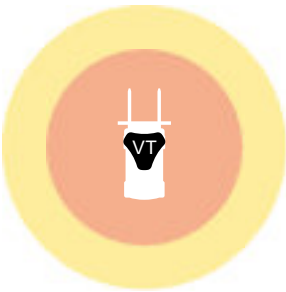
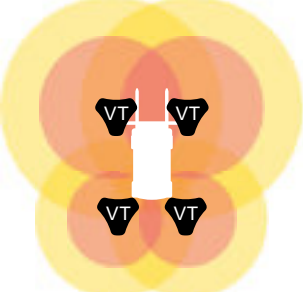
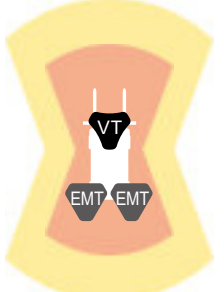
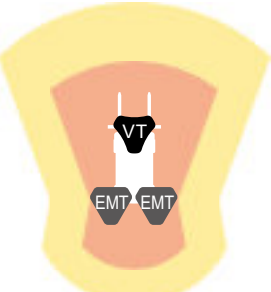
S-Mode (Standard Mode) Caution/Danger zone setting based on distance		E-Mode (Extended Mode) Caution/Danger zone setting of front and rear based on distances and angles	
Single VT Caution/Danger zone setting based on 1 VT.	Multi VTs Caution/Danger zone setting based on MAX 4 VTs.	Static Shaping Caution/Danger zone setting based on distances and angles	Dynamic Shaping Caution/Danger zone setting based on distances and angles by the vehicle's moving direction
			

※ 1 VT and 2 EMTs must be installed to use E-Mode.

### ● Zone Setting

- Caution zone: Area that requires safety precautions / ● Danger zone: Area with high risk of safety accidents
- Setting range of Caution/Danger zone: PT↔VT, VT↔VT/ 1~30m (In 10 centimeter increments)

## 2. Safety Warnings

---

- Failure to follow the cautions/warnings in this manual may result in product failure or serious injury.
- This product is a safety assistant device that generates an alarm by measuring the distance between tags in industrial sites.
- We are not responsible for any damage to people or property caused by violation of safety rules, careless use, etc. Be sure to carefully and fully read the manual until the end before installation.
- Any accident resulting from failure to follow the instructions in this manual is being considered as the user's responsibility.

### Cautions

- Do not place the product near flammable substances, stoves, candles, or fire. Fire or product deformation may occur.
- Do not intentionally submerge the product in water or wash it under running water. It may cause a malfunction.
- Turn off the power and contact your sales office immediately if the product emits odor, smoke, or abnormal noise.

### Warnings

- Do not touch power connectors and wiring with wet hands. It may cause electric shock or fire.
- Do not place heavy objects on the products/wires or subject it to impact. It may cause electric shock or fire.
- If the power connector and wiring get wet, wipe them with a dry towel. Otherwise, it may cause electric shock or fire and contact failure may occur due to corrosion of the connector.
- Do not disassemble or modify the product arbitrarily. It may cause a malfunction, and after-sales service is not possible.
- Do not disconnect the cable while the power is ON.
- Pedestrian Tag (PT) is a rechargeable product. Do not replace the battery because there is a risk of explosion if the battery is replaced with an unsuitable type.
- Pedestrian Tag (PT) is a product with a built-in battery. Store it in a cool place, avoiding direct sunlight when not in use.

## 3-1. Installation | How to Install (Common to all Products)

### ! Precautions before installation

- Be sure to install with the vehicle's power turned off. Turn on the power after connecting all products.
- The vehicle may be discharged in case of connecting the product's power directly to the vehicle's battery. After key-on, be sure to connect the power line to the one that is applied with power.
- When connecting the male and female terminals of the cable, be sure to turn the terminal connection part. Moisture, water, or other liquids may cause malfunction.

### ! Important Notice for Extended Mode Installation

- To ensure proper E-mode functionality, Vehicle Tag and Extended Mode Tag must be installed in locations with a clear Line of Sight (LOS).
- Accurate detection may be affected if LOS is not strictly maintained.

### ● CAN Communication Resistor Setting

- For the stability of CAN communication, only IND+, VT, ZT and FZT shall be installed at the closest and farthest locations from the power supply.
- When installing 2 or more products on 1 power supply
  - ① Products installed closest and farthest from the power supply: Set to **Activated**
  - ② All products installed in the middle: Set to **Deactivated**
- ※ IND+ is always in the Activated state, therefore, no separate setting is required.
- When shipped, VT/ZT/FZT termination resistor setting is set to Activated. Change it to Deactivated for devices installed in the middle using the following method.
- Termination Resistor Value Setting
  - ① IND+- System Setting - Termination Resistor Setting (See page 21)
  - ② KIGIS® Manager Mobile Application

[Ex. 1] Installation of one IND+ and one VT

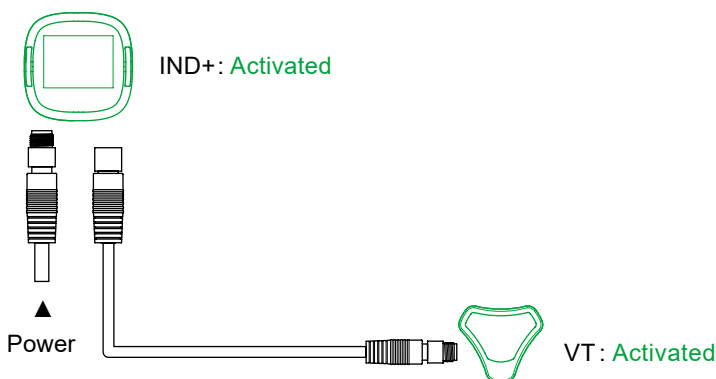

### 3-1. Installation | How to Install (Common to all Products)

#### [Ex. 2] Installation of one IND+ and multiple VTs

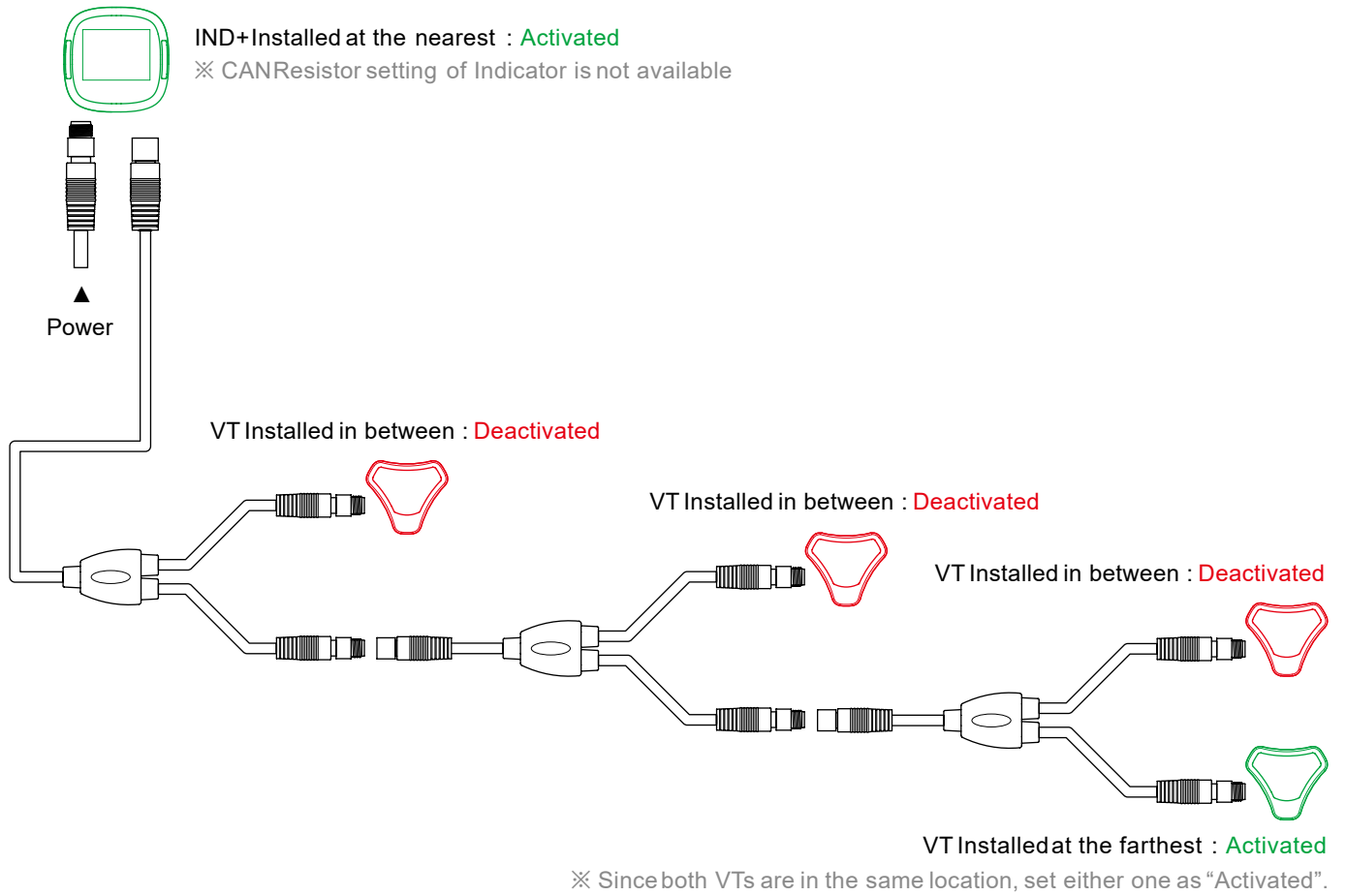

#### [Ex. 3] Installation of one VT (without IND+)

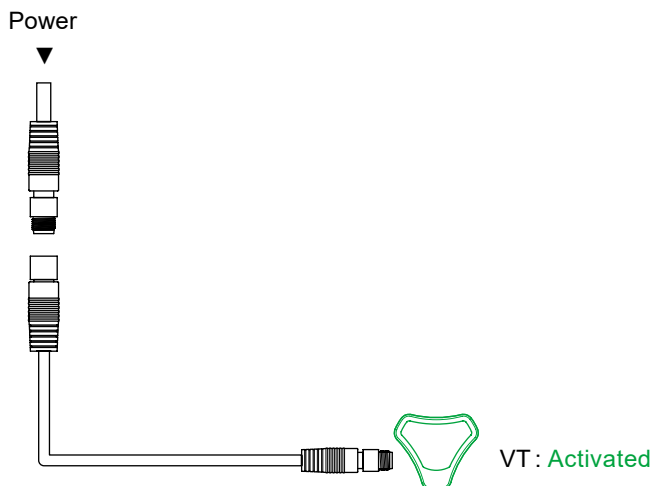

### 3-1. Installation | How to Install (Common to all Products)

[Ex. 4] Installation of multi VTs(without IND+)

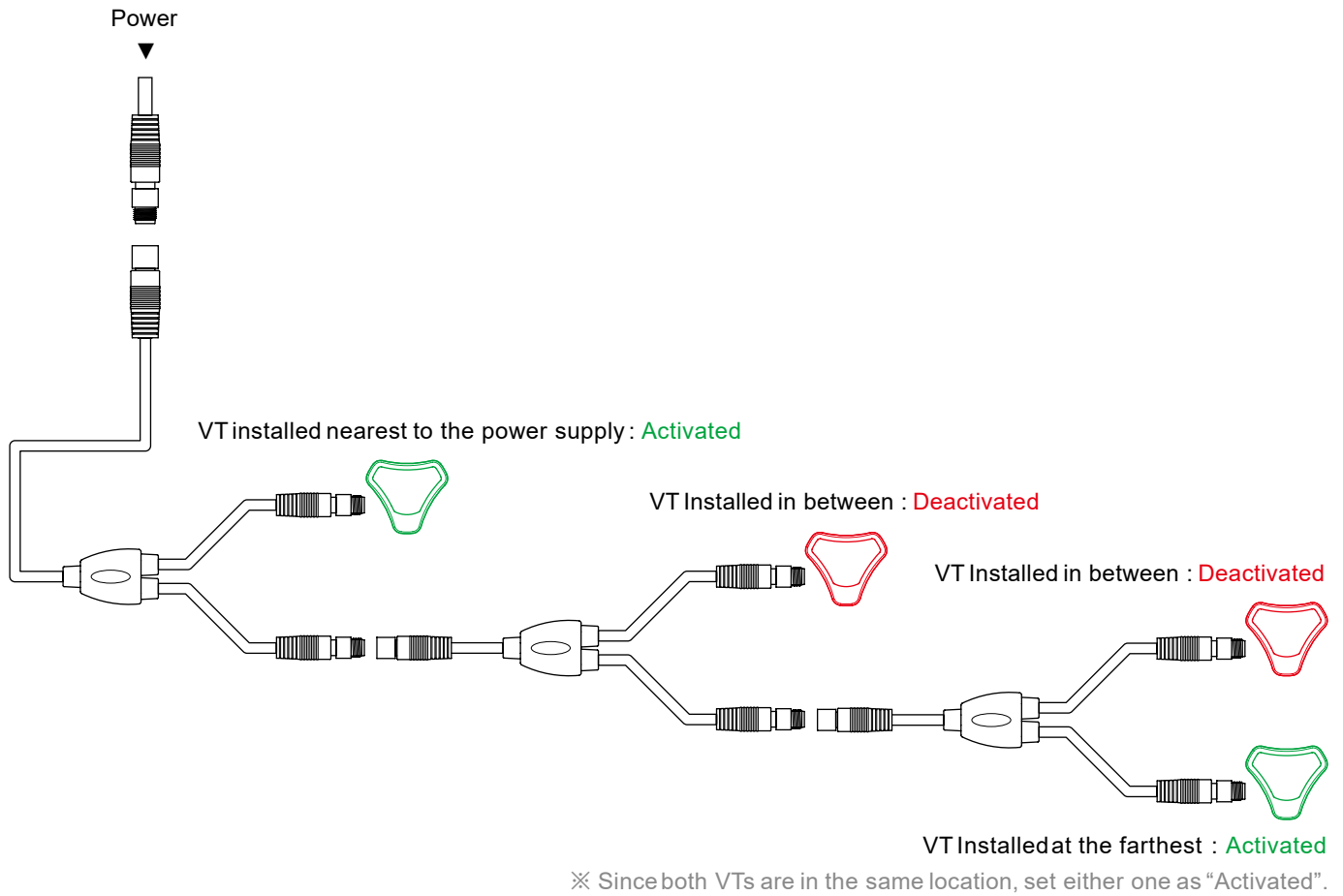

[Ex. 5] Installation of ZT or FZT

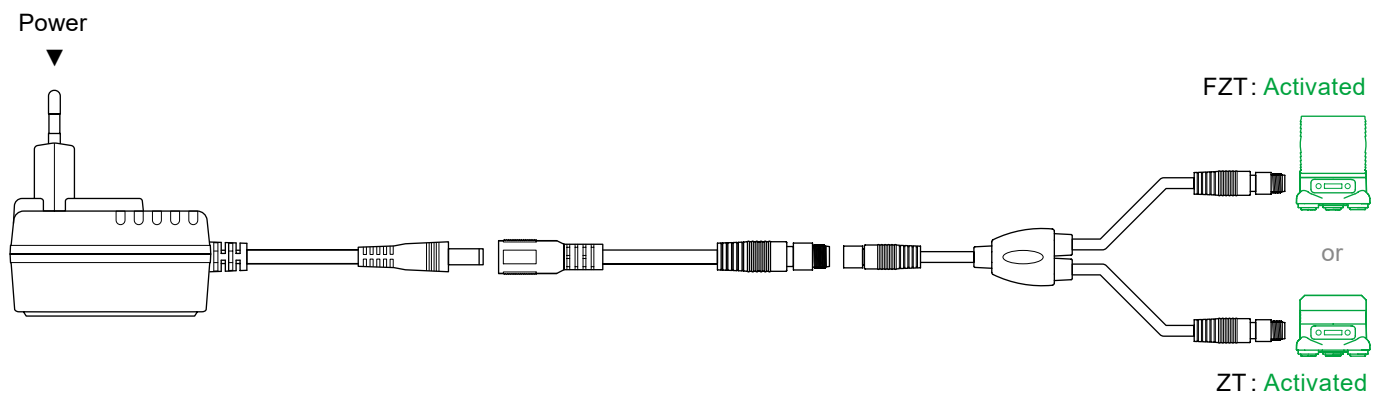

### 3-2. Installation | S-Mode/ Single VT

• How to Install

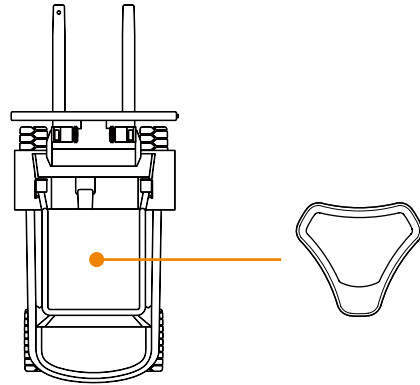
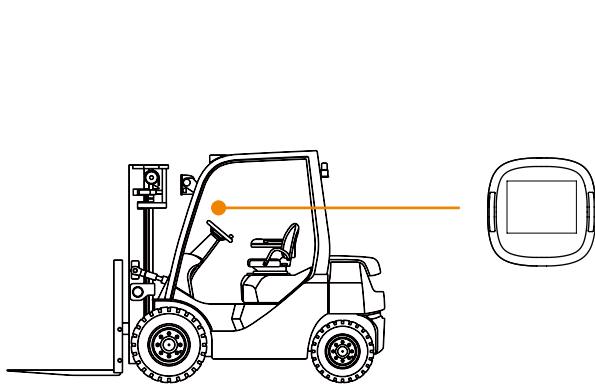

- Vehicle power ON: IND+'sLED first lights up and turns off. Then, LCD screen turns on
- Tag detection : IND+'sLCD shows information and then LED blinks

- Recommended for installation in 360° open spaces such as the top of the vehicle (Wireless communication way)
- Easy installation by attaching with a magnet on the bottom of VT

• Connection Diagram

PAS2-INDP  
Activated

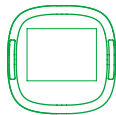

Digital Output Specifications

- Output Voltage : 12~48Vdc · Max. Output Current : 2A

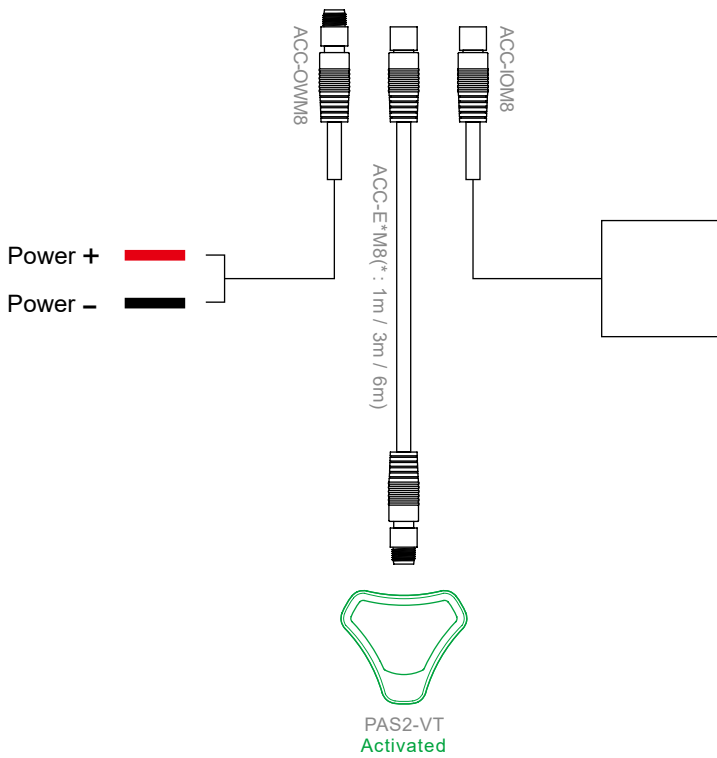

EOD\_In(White, Brown)  
: External Power Input  
Output CH.1 In

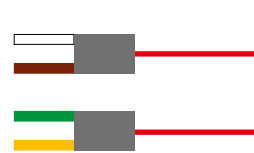

EOD\_Out(Green, Yellow)  
: External Load Power Input  
Output CH.1 Out

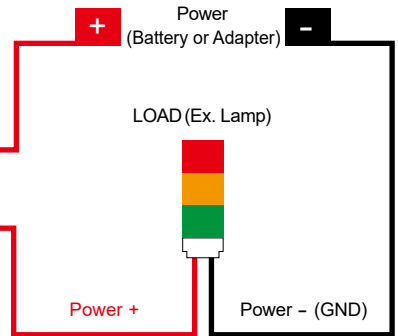

### 3-3. Installation | S-Mode/ Multi VTs

#### • How to Install

Up to 4 VTs can be installed for large vehicles or when wider range is required.

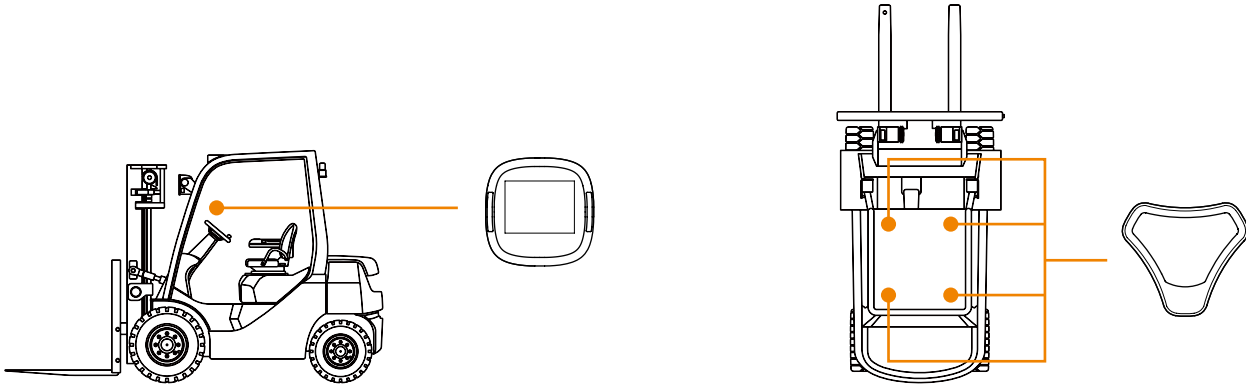

- Vehicle power ON: IND+'sLED first lights up and turns off. Then, LCD screen turns on
- Tag detection : IND+'sLCD shows information and then LED blinks

- Recommended for installation in 360° open spaces such as the top of the vehicle (Wireless communication way)
- Easy installation by attaching with a magnet on the bottom of VT

#### • Connection Diagram



#### Digital Output Specifications

- Output Voltage : 12~48Vdc · Max. Output Current : 2A

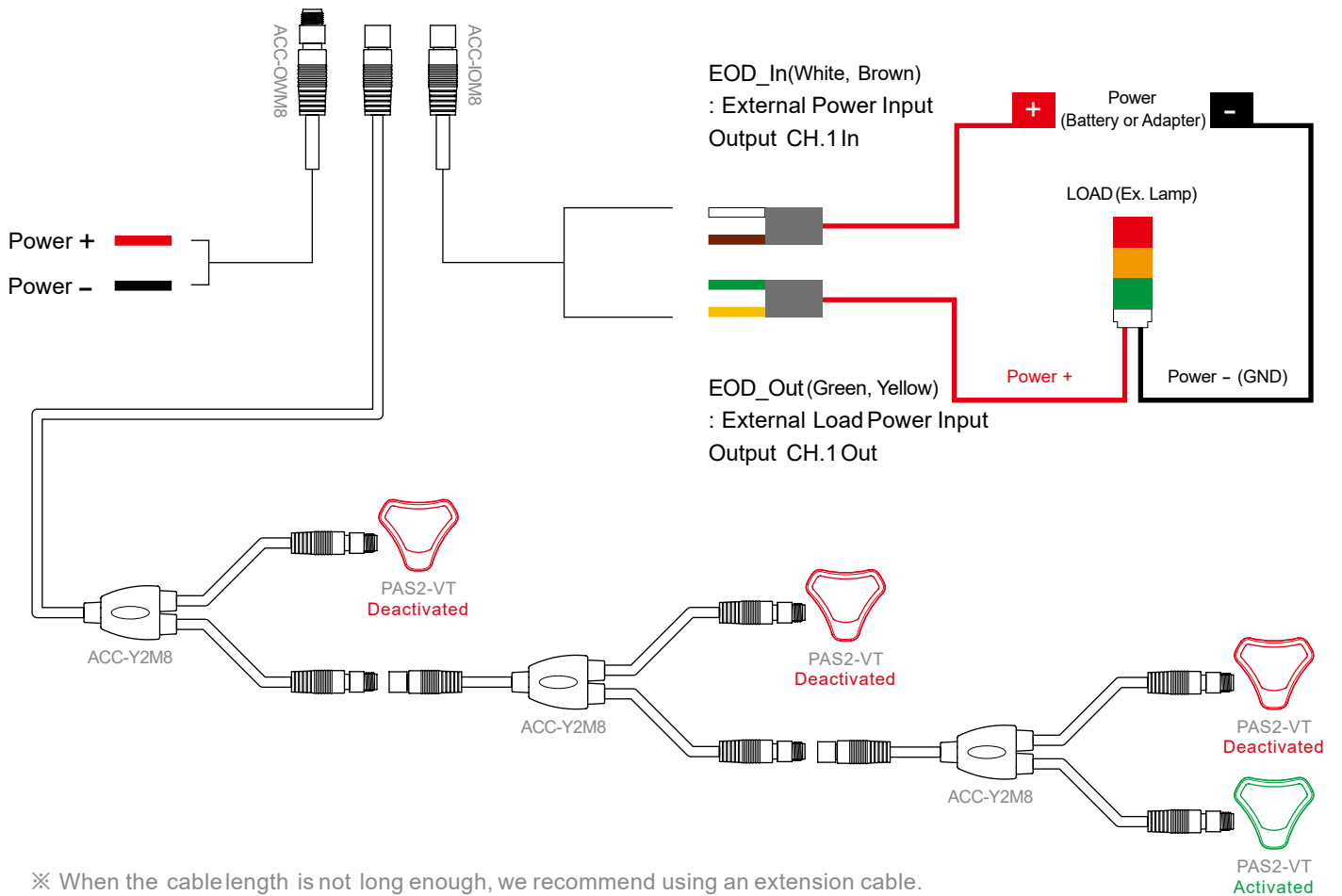

※ When the cable length is not long enough, we recommend using an extension cable.

Product code : ACC-E\*M8(1m / 3m / 6m)

※ When connecting wires, twist the wires first and then connect.

### 3-4. Installation | E-Mode/ Static Shaping

#### How to Install

More customized caution/danger zones can be set based on the distance and angle between the VT and 2 EMTs installed on the vehicle.

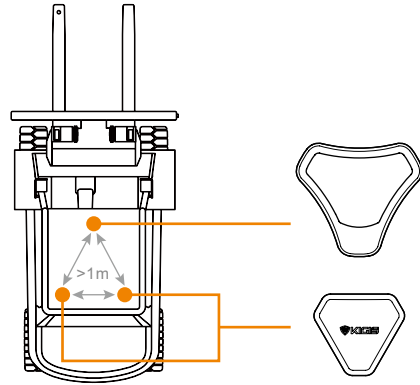
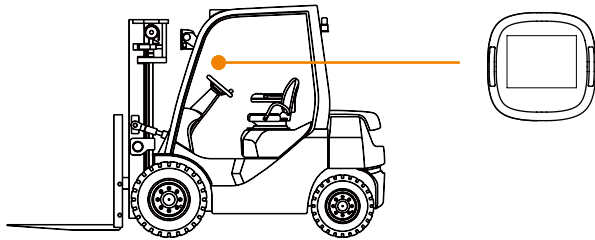

- Vehicle power ON: IND+'s LED first lights up and turns off. Then, LCD screen turns on
- Tag detection : IND+'s LCD shows information and then LED blinks

- One VT and two EMTs must be installed to use E-Mode.
- Install the devices at intervals of at least 1 meter and within 3 meters of each other.
- Do not install any obstacles between the VT and EMT.
- Installation must satisfy LOS (Line Of Sight) Conditions among VT, EMT, and PT.
- After installing VT and EMT, measure the actual distance and enter the location value. (See page 18)

#### Connection Diagram

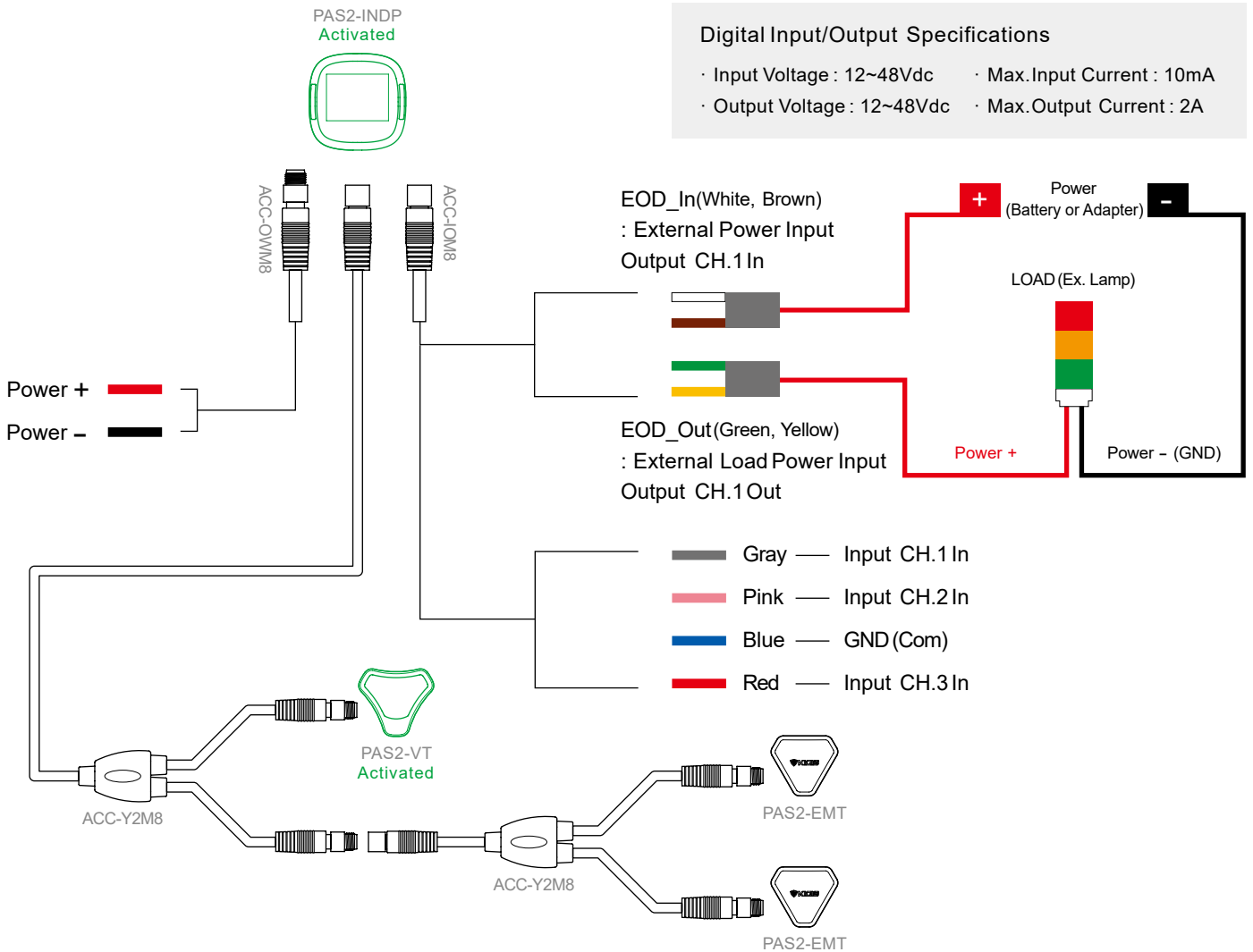

- ※ · There is no need to set the termination resistor value for the EMT.
- For E-Mode installation, refer to IND+ / E-Mode settings. (see pages 18~19)

### 3-5. Installation | E-Mode/ Dynamic Shaping

● How to Install

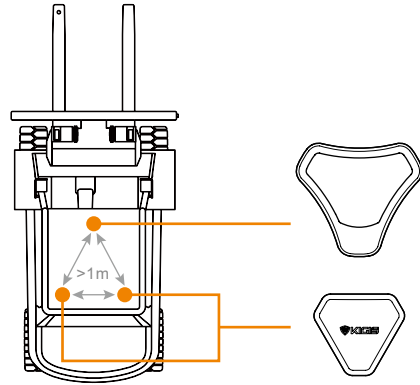
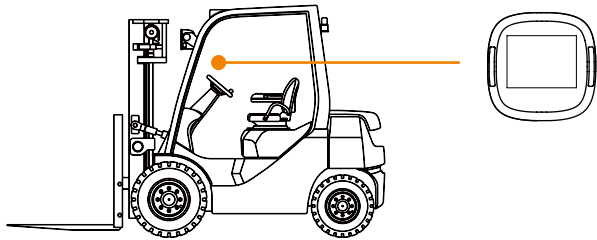

- Vehicle power ON: IND+'sLED first lights up and turns off. Then, LCD screen turns on
- Tag detection : IND+'sLCD shows information and then LED blinks

- One VT and two EMTs must be installed to use E-Mode.
- Install the devices at intervals of at least 1 meter and within 3 meters of each other.
- Do not install any obstacles between the VT and EMT.
- Installation must satisfy LOS (Line Of Sight) Conditions among VT, EMT, and PT.
- After installing VT and EMT, measure the actual distance and enter the location value. (See page 18)

● Connection Diagram

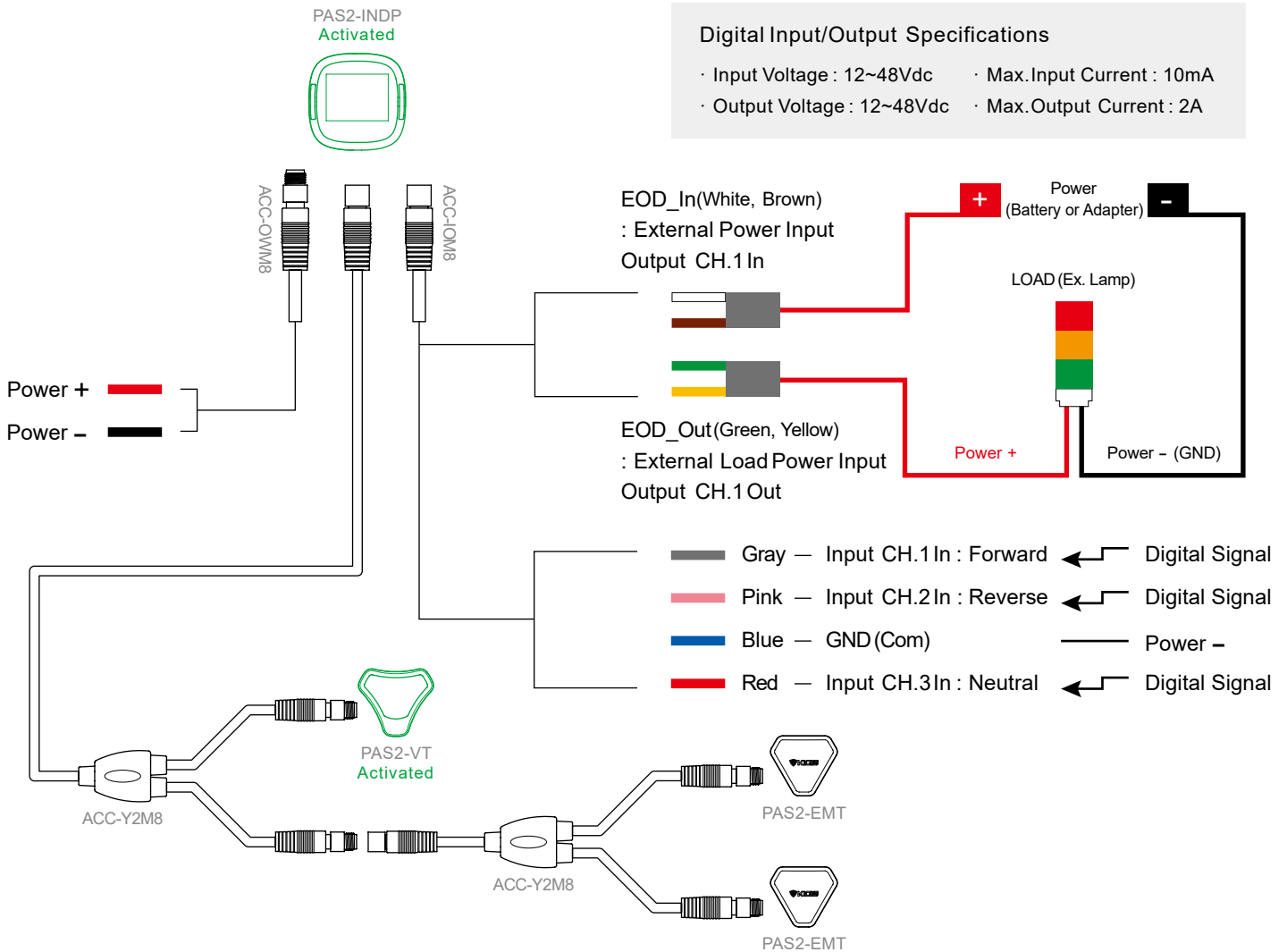

**Digital Input/Output Specifications**

- Input Voltage : 12~48Vdc
- Max. Input Current : 10mA
- Output Voltage : 12~48Vdc
- Max. Output Current : 2A

※ · In order to apply Dynamic Shaping, a digital input signal connection between the ACC-IOM8 cable and the vehicle is required.  
 · For Active / Input signal settings, refer to Dynamic Shaping - ⑧ (see page 19)  
 · When the cable length is not long enough, we recommend using an extension cable.  
 Product code : ACC-E\*M8(1m / 3m / 6m)  
 ※ When connecting wires, twist the wires first and then connect.

### 3-6. Installation | ZT/ FZT

● Connection Diagram

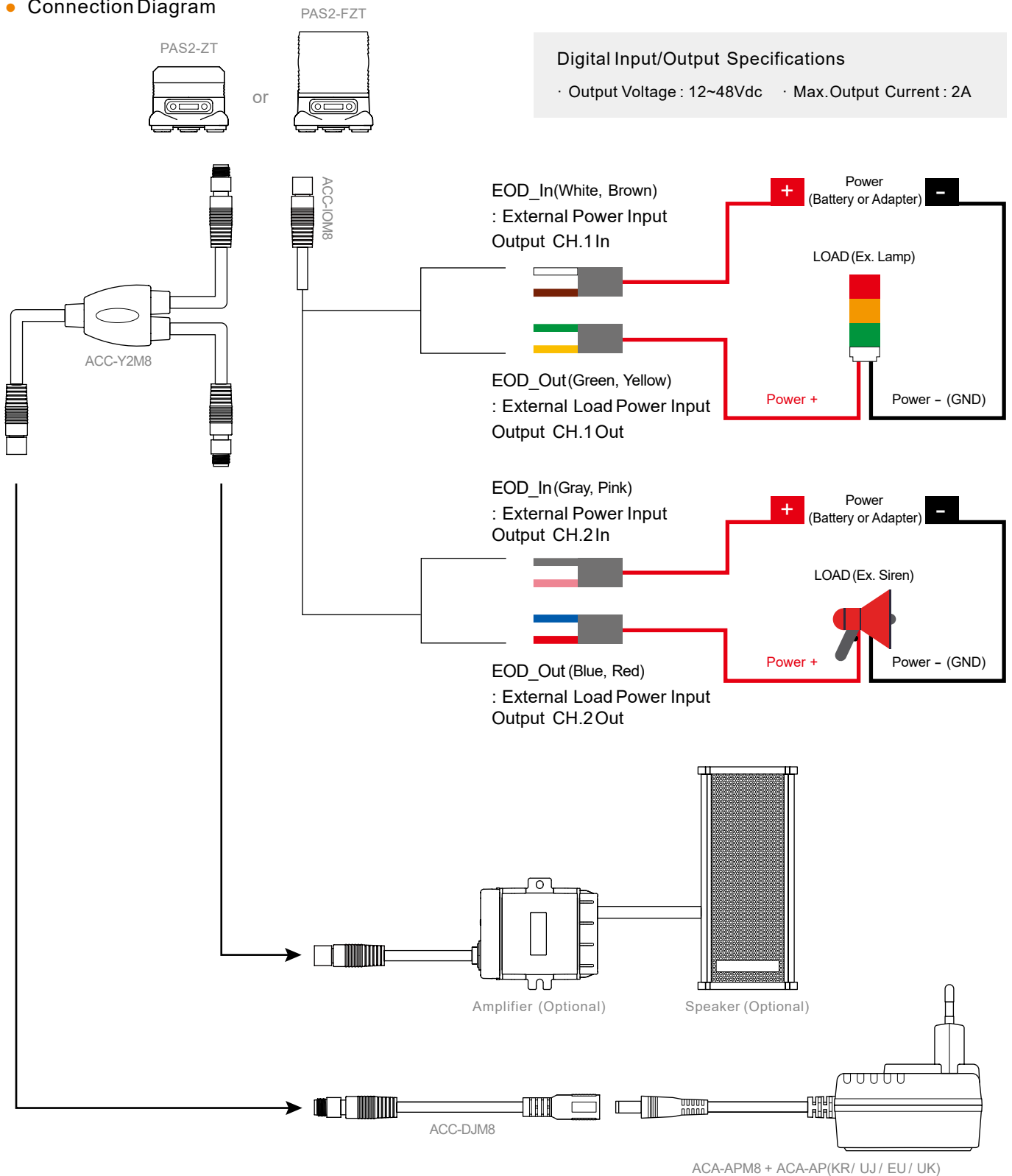

⚠ Safety Warnings

- For the direct installation of ZT or FZT to a facility, a magnetic mount shall be attached to a steel material in order to have the products firmly attached.
  - Adhesion may be weak : ① when the thickness of the adhesive coating is excessive.  
② when the material of the attachment target is not iron.  
(metals such as aluminum and stainless steel may have weak adhesion)  
※ We are not responsible for any damage caused by the magnet mount not being firmly attached.
- 14 · For the safety of the user, ZT and FZT must be installed at a height of 2 meters or less.

### 3-6. Installation | DZT

• How to Install

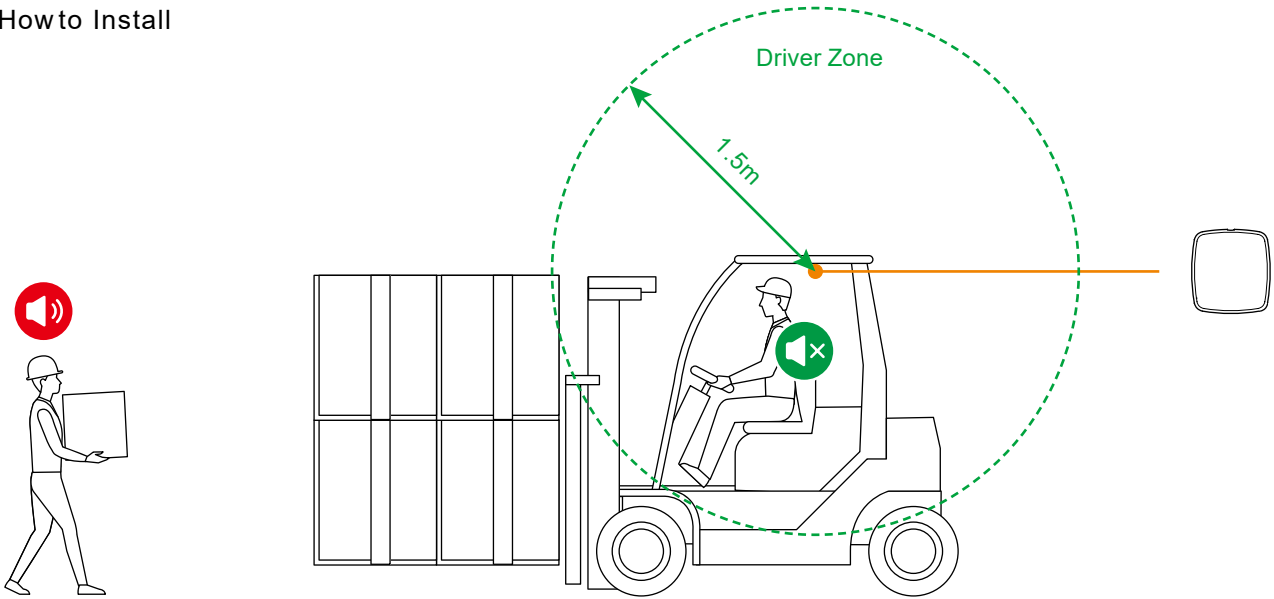

- PT alerts are automatically disabled within the driver zone, defined as a fixed 1.5-meter radius from the Driver Zone Tag.
- The DZT's LED is automatically activated whenever a PT is detected within the driver zone.
- To ensure system integrity and operational safety, the driver zone radius is preset and cannot be modified.
- Easily install the DZT inside the vehicle cabin using built-in magnets on the device base, enabling secure and tool-free attachment to any metal surface.
- Maintain a clear line-of-sight (LOS) between UWB tags to support signal quality and uninterrupted device communication.

• Connection Diagram

Digital Input Specifications  
 · Output Voltage : 12~48Vdc

External Power - Power supply from external

IND+ Power - Power supply directly from IND+

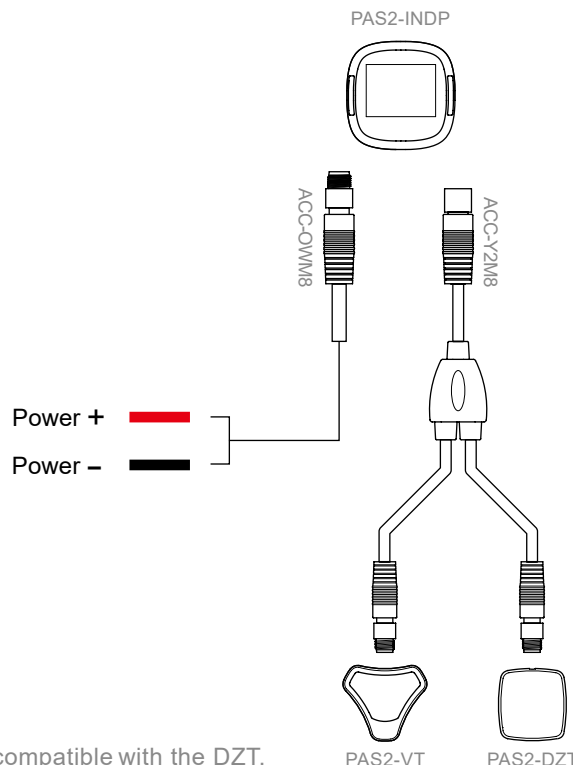
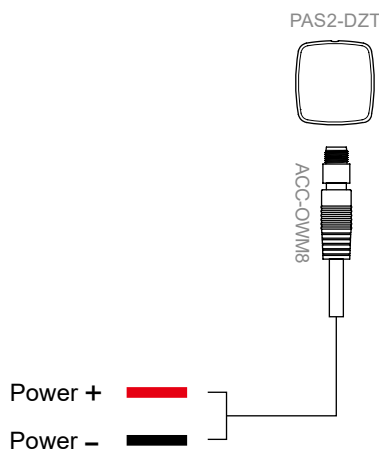

※ PT must be updated to firmware version V1.1.0.0 or later to be compatible with the DZT.

## 4-1. Setting | IND+

### • DeviceLayout

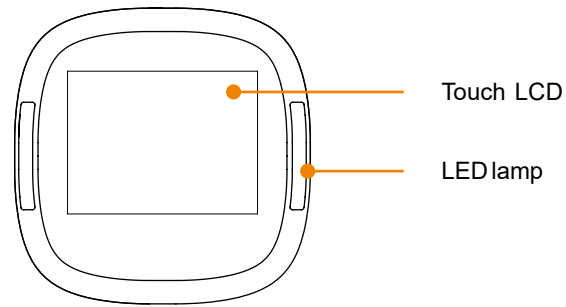

### • Main Display

Displays detection target area

- Caution ● Danger

· Normal state :  
Touch once → Volume control

· Alert occurs :  
Touch once  
→ Buzzer and LED stop for 10 sec.  
Touch twice  
→ Buzzer, LED, and output remain stopped.

S-Mode / Single VT

Menu

Detection target information

	Pedestrians entering caution zone		Pedestrians entering danger zone
	Vehicles entering caution zone		Vehicles entering danger zone

※ A new alarm is triggered when a new PT or VT is detected.



S-Mode / Mutl VTs (2 VTs)

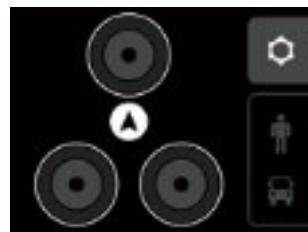

S-Mode / Mutl VTs (3 VTs)



S-Mode / Mutl VTs (4 VTs)



E-Mode

### • Setting

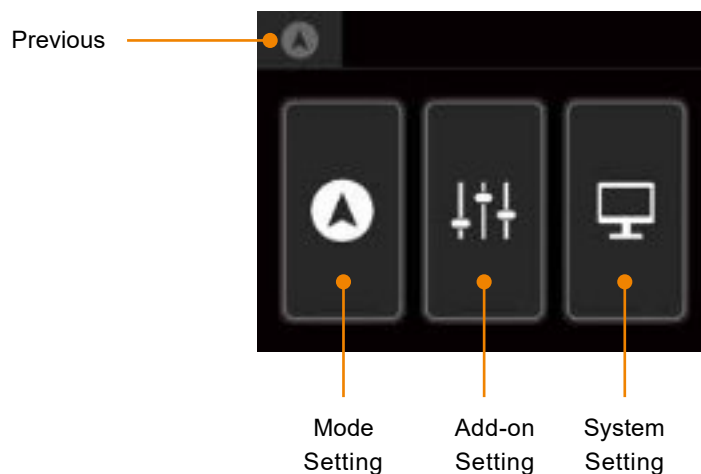

## 4-2. Setting | IND+/ S-Mode Setting

### ● S-Mode/ SingleVT

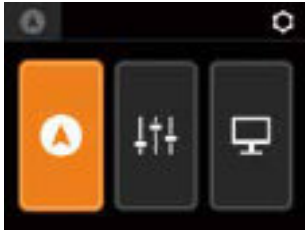

① Select "Mode"

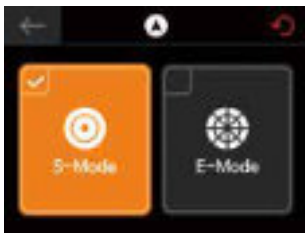

② Select "Reset (🔄)" and Select "S-Mode"

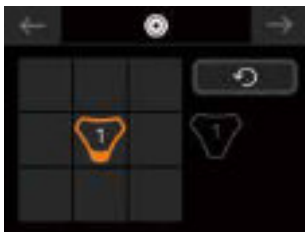

③ Automatic VT position setting



④ VT ↔ PT Caution/Danger distance setting

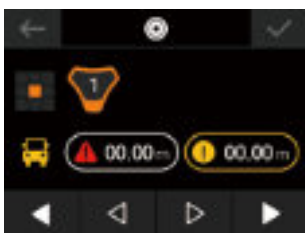

⑤ VT ↔ VT Caution/Danger distance setting

### ● S-Mode/ Multi VTs

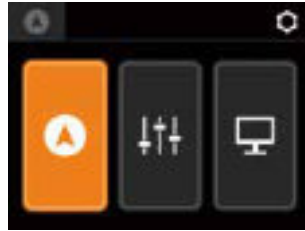

① Select "Mode"



② Select "Reset (🔄)" and Select "S-Mode"



③ VT position setting (Upon the selection of VT icon, the corresponding VT LETlights up.)

 Location Reset



④ Selected VT ↔ PT Caution/Danger distance setting



⑤ Selected VT ↔ VT Caution/Danger distance setting

## 4-3. Setting | IND+/ E-Mode Setting

### • How to Input Coordinate

- Reference point : Coordinate value (0.0)
- Install at 1m to 3m intervals for each product.
- 2 EMTs shall be installed horizontally and 1 VT shall be installed within the range where 2 EMTs are installed.

- ※ All tags shall be installed at the same height.
- ※ A larger difference between the entered coordinates and the actual installation location may lead to greater detection inaccuracies.

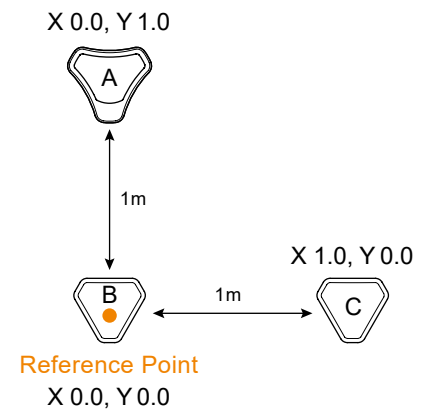
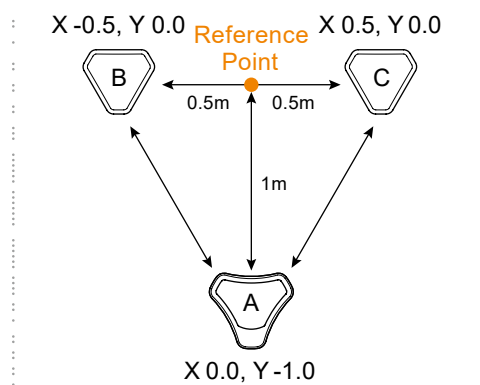
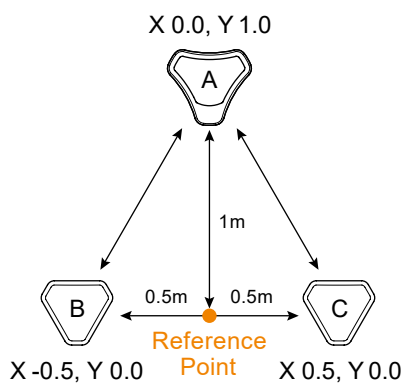

### • E-Mode/ Static Shaping

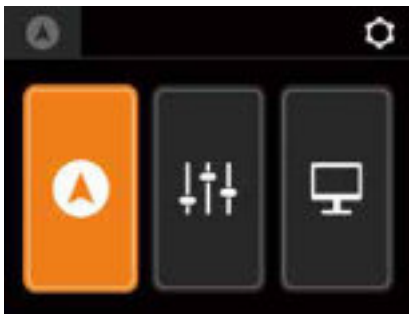

① Select "Mode"



② Select "Reset" and Select "E-Mode"

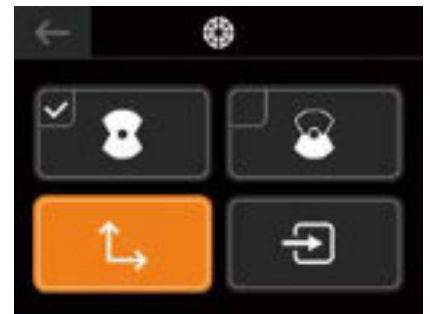

③ Select "VT / EMT coordinate Setting"



④ Input VT/EMT coordinate (See page 18)

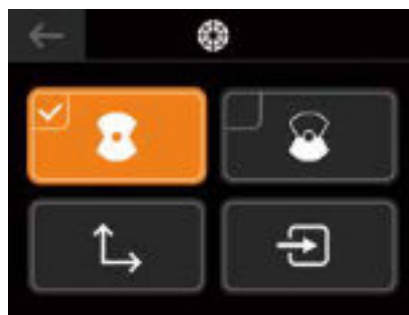

⑤ Select "Static Shaping"

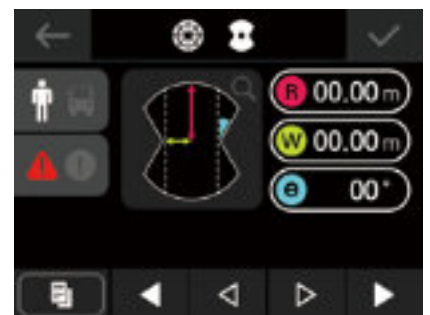

⑥ Set Warning/Danger zone by entering distance & angle (front/rear, left/right) from the reference point  
Copy value

## 4-3. Setting | IND+/ E-Mode Setting

### • E-Mode/ Dynamic Shaping

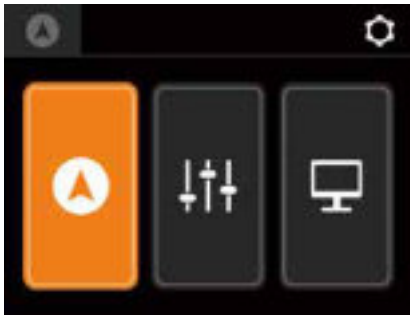

① Select "Mode"

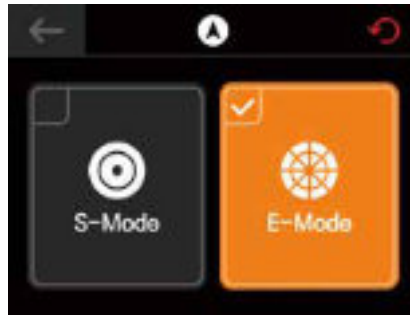

② Select "Reset" (🔄) and Select "E-Mode"

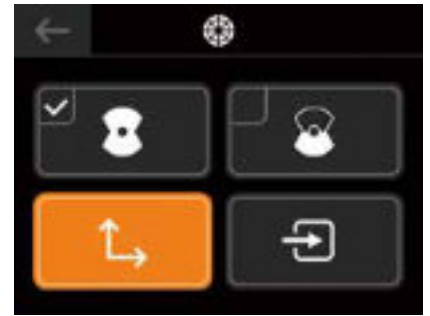

③ Select "VT/ EMTcoordinate Setting"



④ Input VT/EMTcoordinate  
(refer above table)

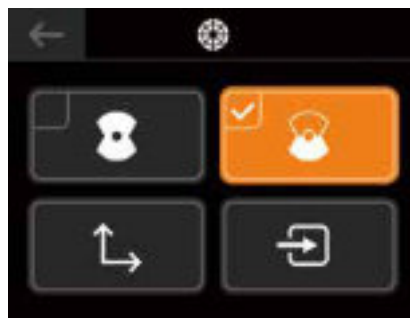

⑤ Select "Dynamic Shaping"



⑥ Set Warning/Danger zone by entering distance & angle (front/rear, left/right) from the reference point  
📄 Copy value

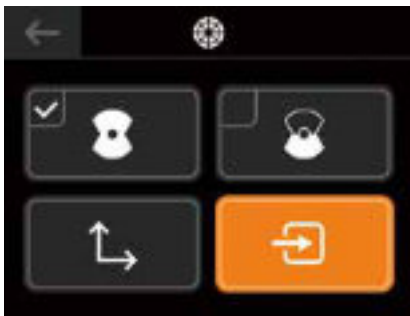

⑦ Select "Digital Input"



⑧ Active value and activate Input signal  
 · F : Forward (Applies forward detection range)  
 · R : Reverse (Applies backward detection range)  
 · N : Neutral (Alarm cancel state)

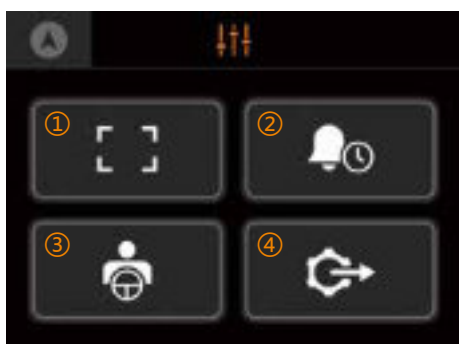
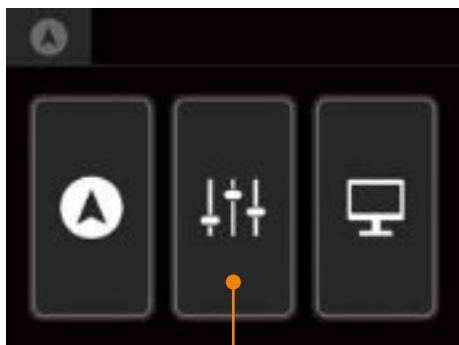

① Detection Target Setting  
PT, VT, ZT

② Alarm cancellation time  
Set PT/ VT alarm time (0 to 10 second)

③ Pedestrian Tag Registration  
When registered PT is detected, alarms are disabled on IND+/ VT (Max. 5 PTs can be registered)

④ Output function  
When PT is detected, the signal is output through the wire connected to Output CH.1 of the IND+ACC-IOM8 cable for the configured duration.

① Detection Target Setting



Select detection target (PT/ VT/ ZT)  
 · PT,VT : Activate alarm and output function  
 · ZT : Activate output function  
 ※ If not selected, IND+/ VT alarms will not be activated

② Alarm Cancellation time

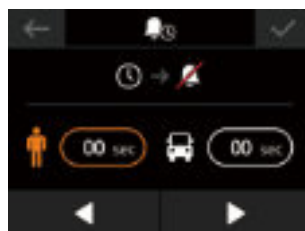

Setting range : 0 to 10 seconds  
 · 0 : Alarm continues  
 · Any value other than 0 : Alarm will sound for the specified duration, then automatically stop.

③ Pedestrian Tag Registration



· PTSearch : Search button on the right  
 · PTRegistration : Move the PT from the right to the left  
 · PTDeregistration : Move the PT from the left to the right

④ Output function



· Select detection target (PT/ VT/ ZT)  
 · If the release time is set to 0 : Multiple selections of PT, VT, and ZT are allowed, and a continuous signal is output when detected.  
 · If the release time is not 0 : Only one of PT, VT, or ZT can be selected, and the signal is output only for the specified duration.  
 · When Driver is selected, the release time is automatically set to 0. If a registered PT is detected, the signal is output through the wire connected to Output CH.1.

- Default Mode (Reverse Unchecked)
  - EOD Power ON : Signal OFF
  - EOD Detected : Signal ON
- Reverse Mode (Reverse Checked)
  - EOD Power ON : Signal ON
  - EOD Detected : Signal OFF

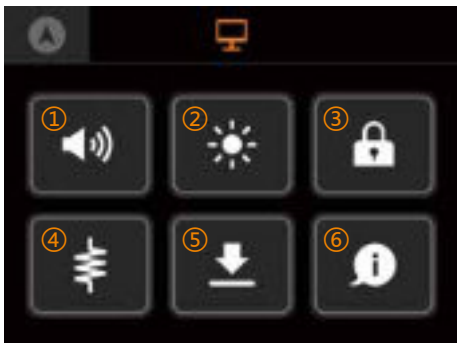
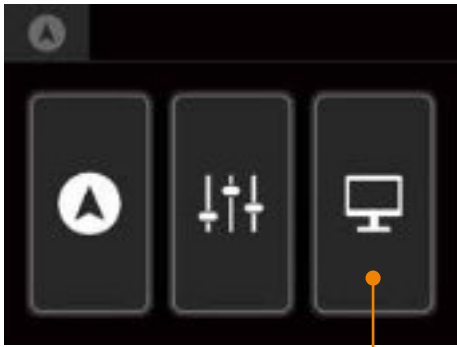

- ① Volume
- ② LCDbrightness
- ③ Password change
- ④ Termination resistor setting
- ⑤ Firmware update
- ⑥ System information

① Volume



Volume value setting  
(0 to 10 levels)

② LCDbrightness



Brightness control of LCD  
(0 to 5 levels)

③ Password change



4-digit password setup  
(Initial password : 0000)  
※ If you forget your password, please contact the administrator.

④ Termination resistor setting



- Termination resistor setting for connected VT
- Only 1 VT shall be activated to keep CAN communication stabilized when installing multi VTs (See page 7)

⑤ Firmware update



IND+, VT, EMT update

⑥ System information

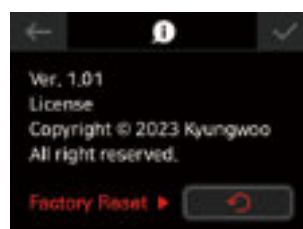

- Firmware version, ID information
- Factory reset (reset all settings and passwords)

## 4-6. Setting | PT

### • Device Layout

#### Power/Menu

##### • Power On/Off

- Press and hold for more than 2 seconds
- On : LED blinks, then turns on
- Off : turns off after beep

##### • Alarm Setting

- Select Sound, Vibration, or Sound + Vibration
- Press twice quickly while powered on (Settings are saved after 30 seconds)

##### • Alarm stop

- Press 1 time : Alarm stops for 10 seconds
- Press 2 times: Alarm turns off
- Alarm will resume if triggered again.
- Alarm cannot be stopped if button lock is enabled.

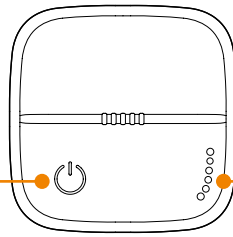

#### LED Lamp

- Displays 4-level battery status when powered on
- Sequential LED indication during app pairing standby
- Dual sequential LED indication upon app connection

※ When locked, power On/Off is disabled. Alarm settings can be changed only when the alarm is not active.

### • Alarm Setting



### • KIGIS® Manager Mobile App Pairing Guide

#### ① Pairing

- With PT powered on, double-press the button
- LEDs sequence with beep enters pairing mode for 30 seconds

※ Pairing available only when alarm is inactive

#### ② Unpairing / Cancel

- Press and hold the button to disconnected when paired
- Press and hold the button to cancel pairing mode during standby

### • How to Wear PT

It is necessary to wear PT in the correct position for reliable use.

Make sure to wear correctly, so that PT is not covered by any part of the body.

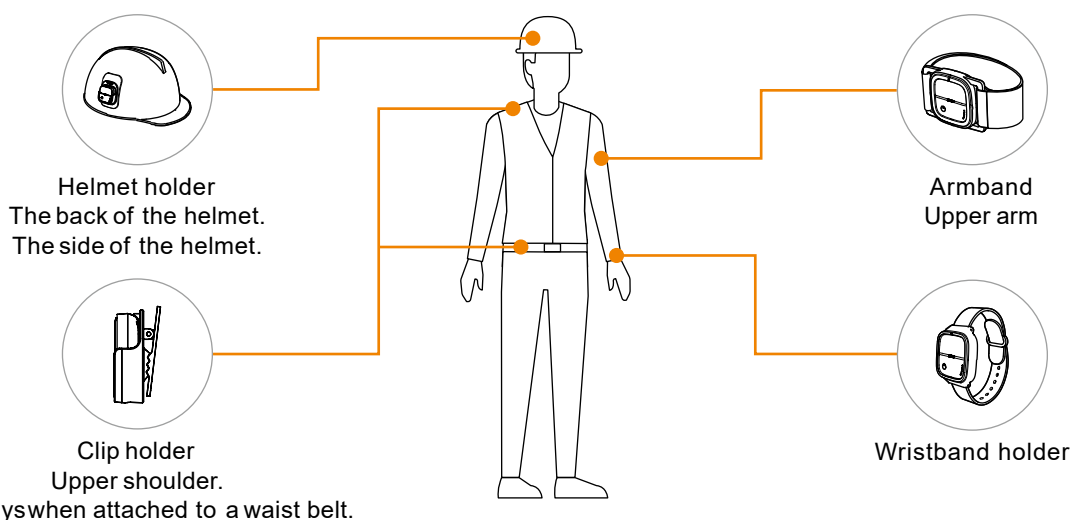

## 4-7. Setting | ZT/ FZT

### • Device Layout

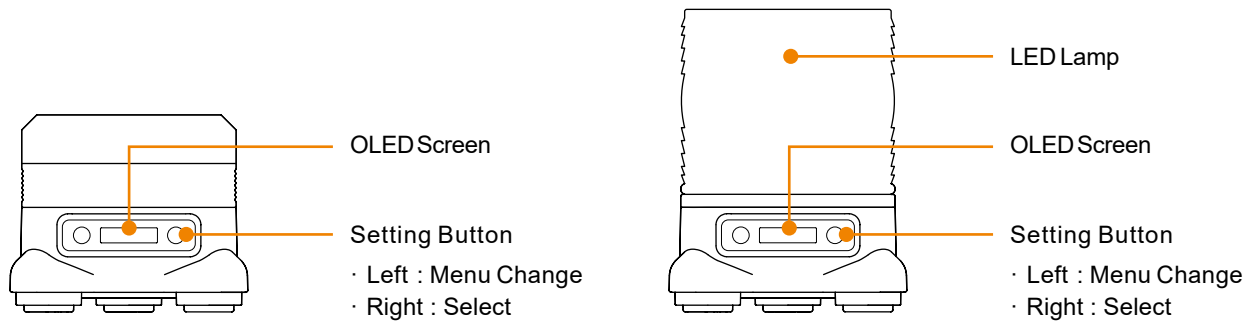

### • Setting

· Basic setting : Danger distance 10m / Caution distance 20m / Alarm sound ON/ Idle time OFF

· Digital output basic setting : Output CH1 : Danger / Reverse mode OFF  
 Output CH2 : Caution / Reverse mode OFF

(※ Calibration and detailed setting : Available by Mobile App 'KIGISManager'[see page 24])

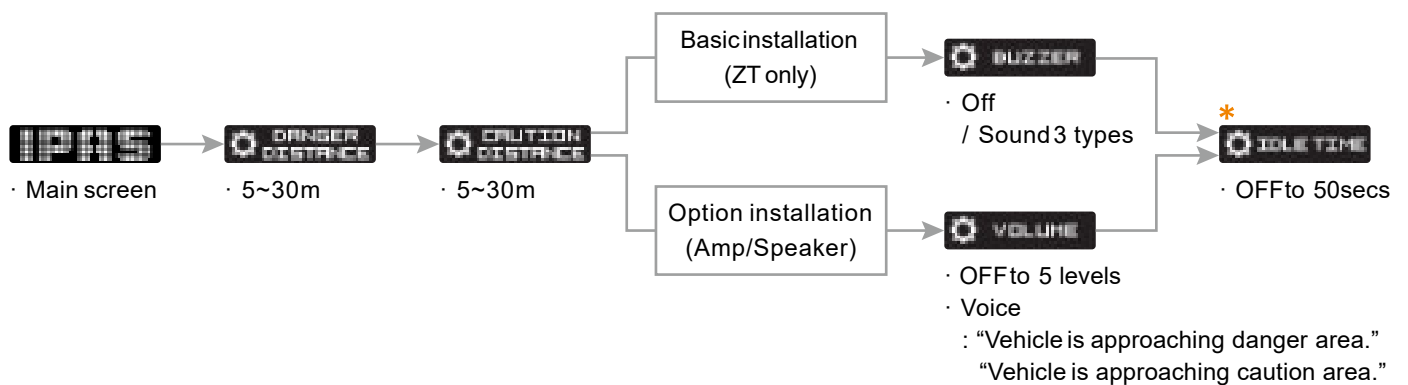

#### \* Idle Time

If a vehicle enters into the caution zone and makes no movement within the preset time, alarm and lamp automatically become deactivated because then the vehicle is considered non-existent.

## 4-8. Setting | KIGIS®Manager Quick Guide

To fully enjoy the various features of KIGIS®products, it is essential to install the dedicated application. This app is available for both iOS and Android platforms and can be easily found by searching for [KIGISManager] in your device's app store. Alternatively, you can quickly install it by scanning the provided QR code.



APP Download

※ For detailed guidance on how to install and use the app, please refer to the separate [KIGIS®Manager User Guide].

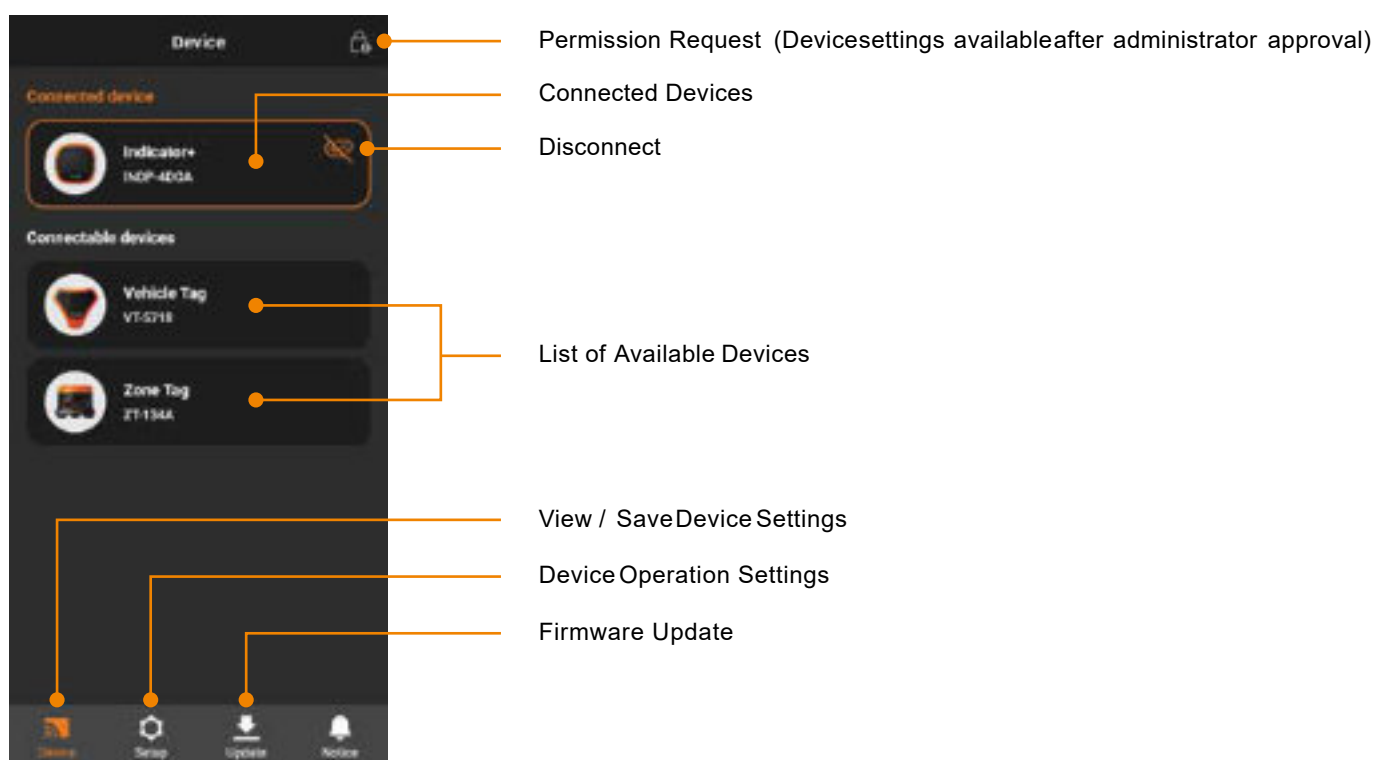

### ● How to Connect IPASSE Devices

#### · IND+, VT

After powering on the device, it will be available for connection for 30 seconds. If more than 30 seconds have passed, please turn the power off and then on again to re-enter connection mode.

#### · PT

After turning on the device, quickly press the button twice. When a beep sounds and the LEDs light up in sequence, the device is ready to connect.

#### · ZT, FZT

Always available for connection.

※ Please ensure that Bluetooth and Location Services are enabled on your smartphone to use the app.

## 5. Prior to Error Reporting

Product	Inquiry	Cause/ Explanation	Solution
IND+	'Vehicle Check' alarm sounds	This may be due to incorrect cable connection or incorrect CAN resistor setting.	<ul style="list-style-type: none"> <li>· Please check the cable connection status.</li> <li>· Please check the CAN resistor setting status.</li> <li>· Please proceed with initialization on the VT mode selection screen.</li> </ul>
	Cannot set the volume to '0'	The minimum volume setting can be found in the system setting.	Please change the minimum volume setting in the system setting.
PT	I can't enter the PT menu.	You can only access the menu when the alarm is not sounding after turning on the power.	When there is no alarm operation, if you press the button twice in succession at 0.5 second intervals, the LED will blink sequentially and you will enter menu mode. Please check if Lock Mode is enabled in the app.
	PT keeps turning off.	Battery needs to be charged.	Charge the battery. All 4 LEDs light up when fully charged.
	PT does not turn off.	Lock Mode may have been applied.	Please check if Lock Mode is on or off in the app.
	PT does not work.	Wireless communication signals may have a reduced recognition rate when penetrating a human body.	For reliable communication environment, please wear the PT correctly and have it exposed in the environment. (See page 22)
The battery may be discharged.		Please check the charging status of the PT.	
VT	VT sound is too small.	Volume setting of Indicator Plus is low.	Volume level can be adjusted in Indicator Plus. (See page 21)
Others	The set danger/caution zone distance seems to be incorrect.	<p>Situation A : The alarm sounds at a horizontal distance shorter than the distance set according to the VT installation height.</p> <p>Situation B : When entering and leaving a Caution/Danger zone, the alarm sounds 1m further away for safety.</p> <p>(Ex. When setting Danger 2m / Caution 4m, Until you go beyond danger 3m / caution 5m (corresponding alarm occurs))</p>	<p>In the situation of A and B, it is normal operation as designed.</p> <p>If there is still a problem, we recommend that you re-set the distance after initializing the indicator.</p> <p>(See page 17~19 for initialization and distance setting)</p>

## 6. Specifications

Product	Indicator Plus (IND+)	Vehicle Tag (VT)	E-Mode Tag (EMT)	Pedestrian Tag (PT)	Standard Zone Tag (ZT)	Flashlight Zone Tag (FZT)	Driver Zone Tag (DZT)
Power Source	12 ~ 48Vdc	12 ~ 48Vdc (from IND+)	12 ~ 48Vdc (from IND+)	Li-Po 350mAH (Typ. 3.8V)	12/24Vdc	12/24Vdc	12 ~ 48Vdc
Operating Time	-	-	-	Up to 54 Hours	-	-	-
Consumption	Max. 500mA(@12V)	Max. 500mA(@12V)	Max. 500mA(@12V)	Max. 500mA(@3.8V)	Max. 500mA(@12V)	Max. 500mA(@12V)	Max. 100mA(@12V)
UWB	-	6.5GHz / 500MHz BW	6.5GHz / 500MHz BW	6.5GHz / 500MHz BW	6.5GHz / 500MHz BW	6.5GHz / 500MHz BW	6.5GHz / 500MHz BW
Display	3.5" Touch LCD	N/A	N/A	N/A	OLED(128×32)	OLED(128×32)	-
Indicator	LED×2EA, Speaker	LED×1 set	N/A	LED×4EA, Buzzer, Vibrator	Buzzer	LED, Buzzer	LED×1set
Interface	Bluetooth 5.0	Bluetooth 5.0	-	Bluetooth 5.0	Bluetooth 5.0	Bluetooth 5.0	-
Detection Distance	-	Max. 30m	Max. 30m	Max. 30m	Max. 30m	Max. 30m	Max. 1.5m
Dimension	110×110×35.2 mm	128×115×64.5 mm	92.3×83×60.75 mm	44×44×14.5 mm	110.4×111.5×91.6 mm	110.4×111.5×140.6 mm	58×62.5×27.4 mm
Weight	235g	320g	175g	21g	355g	450g	90g
Mounting	VESAMount	Magnetic Foot Mount×3	Magnetic Foot Mount×3	Through Holder	Magnetic Foot Mount×3	Magnetic Foot Mount×3	Magnetic Foot Mount×4
Operating Temperature	-20 ~ 70°C	-30 ~ 75°C	-30 ~ 75°C	-20 ~ 60°C	-30 ~ 70°C	-30 ~ 70°C	-30 ~ 85°C
Storage Temperature	-30 ~ 85°C	-30 ~ 85°C	-30 ~ 85°C	-20 ~ 45°C	-30 ~ 85°C	-30 ~ 85°C	-40 ~ 85°C
Charging Temperature	-	-	-	10 ~ 45°C	-	-	-
Enclosure	IP65	IP67	IP67	IP65	IP65	IP65	IP65

※ Specifications are subject to change without prior notice for product improvement or future release.

## Disclaimer

This user manual and product specifications are subject to change without prior notice for product improvement or future release.



· ZE8-KWO-PAS2-VT · ZE8-KWO-PAS2-EMT  
· ZE8-KWO-PAS2-ZT · ZE8-KWO-PAS2-PT  
· ZE8-KWO-PAS2-FZT · ZE8-KWO-PAS2-DZT  
· 2AX9WM02



· R-R-KWO-PAS2-INDP · R-R-KWO-PAS2-EMT  
· R-R-KWO-PAS2-VT · R-R-KWO-PAS2-PT  
· R-R-KWO-PAS2-ZT · R-R-KWO-PAS2-DZT  
· R-R-KWO-PAS2-FZT  
· R-R-1Ae-PRBMD02



### FCC Compliance Information

This device complies with part 15 of the FCC Rules. Operation is subject to the following two conditions: (1) This device may not cause harmful interference, and (2) this device must accept any interference received, including interference that may cause undesired operation.

This equipment has been tested and found to comply with the limits for a Class B digital device, pursuant to part 15 of the FCC Rules. These limits are designed to provide reasonable protection against harmful interference in a residential installation. This equipment generates, uses and can radiate radio frequency energy and, if not installed and used in accordance with the instructions, may cause harmful interference to radio communications. However, there is no guarantee that interference will not occur in a particular installation. If this equipment does cause harmful interference to radio or television reception, which can be determined by turning the equipment off and on, the user is encouraged to try to correct the interference by one or more of the following measures:

- Reorient or relocate the receiving antenna.
- Increase the separation between the equipment and receiver.
- Connect the equipment into an outlet on a circuit different from that to which the receiver is connected.
- Consult the dealer or an experienced radio/TV technician for help.

Part 15.250(c) Operation on board an aircraft or a satellite is prohibited. Devices operating under this section may not be employed for the operation of toys. Except for operation on board a ship or a terrestrial transportation vehicle, the use of a fixed outdoor infrastructure is prohibited. A fixed infrastructure includes antennas mounted on outdoor structures, e.g., antennas mounted on the outside of a building or on a telephone pole.

Changes or modifications not expressly approved by the party responsible for compliance could void the user's authority to operate the equipment.

This device complies with FCC RF exposure requirement.

