

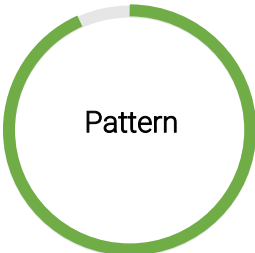

Proportion



## Features

- Red zone lights SP-L349 are used for forklift safety solutions.
- Bright enough with original osram leds chip.
- Long red lines with concentrated light pattern
- Great light pattern by using optical principle of science.
- Long using life with more than 50000 hours.
- Great out looking with easy installing.
- Good quality with 2 year warranty.

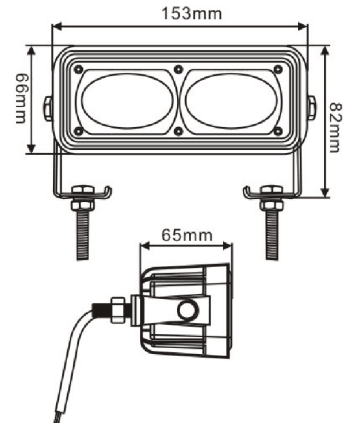

## Specification

Model No.	SP-L349
Led Chip	original osram
LED power	28.1w
Voltage range	10-80V DC/2.34A
Lumen	1600LM
Beam	Red/Blue/Green line
Size	155*66*66 mm
Waterproof rate	IP68
LED lifetime	50000 hours
Housing Material	100%Diecast Aluminum
Lens	PC
Operating temperature	-45 ~85° C
Warranty	2 years
Carton Size	59.5*30.5*28.5cm
Weight(kg/Carton)	19.5kg
PCS/Carton	24pcs



# ESQUENET

Mobile Safety Technology & Forklift Supplies